

One-Step Injection Stretch Blow Molding Machine

ASB Series

ASB-50MB

Entry Machine for Small Containers

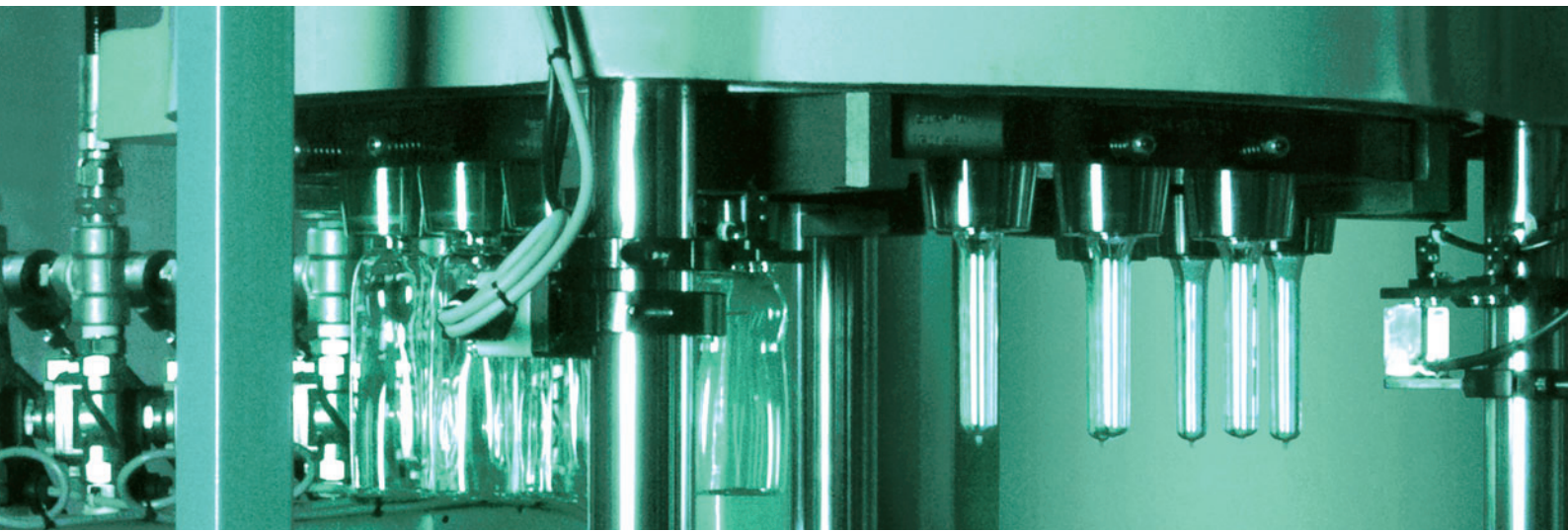

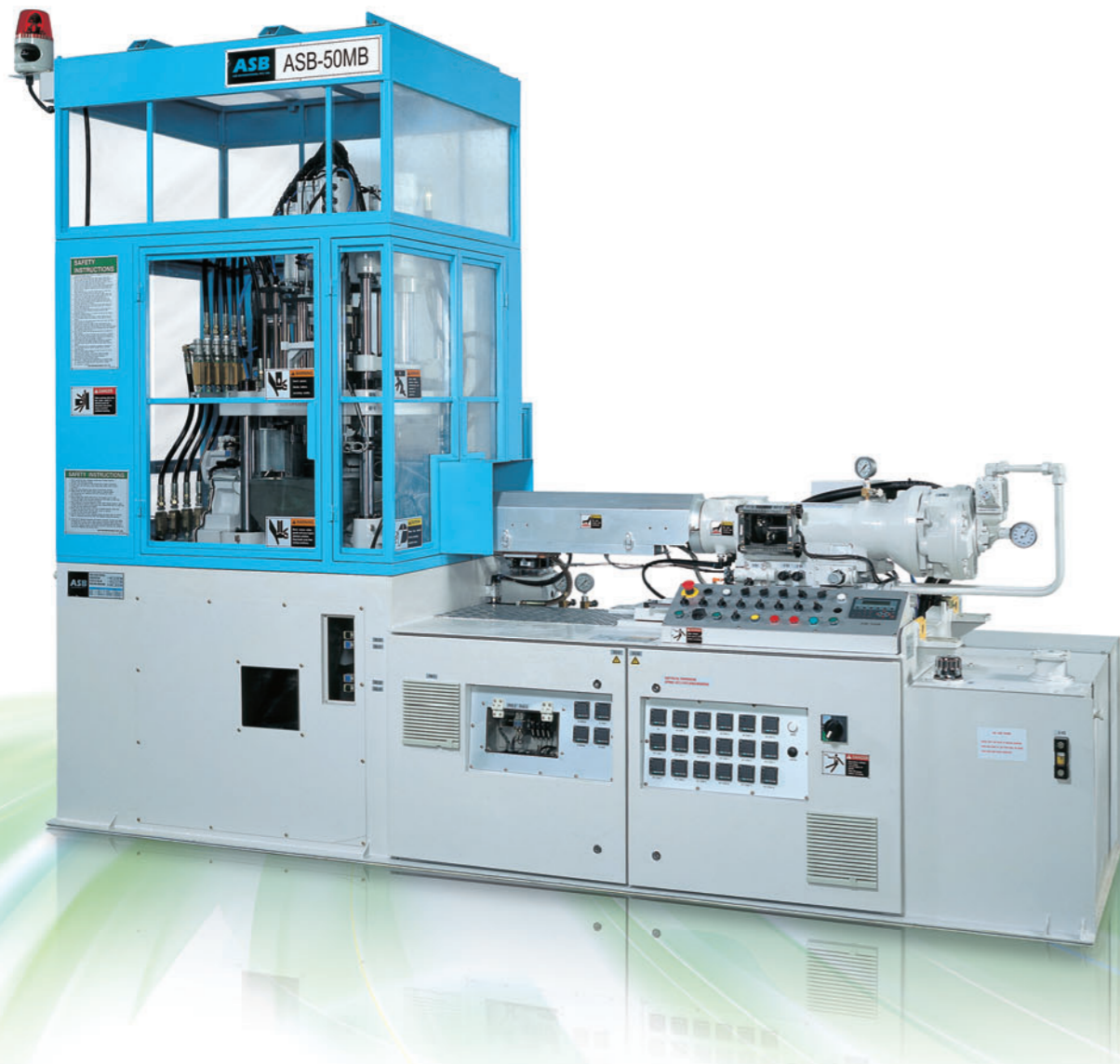

■ Compact & Reasonable

Design, development and production are done by our India factory where lower manufacturing costs allow an extremely attractive selling price. Additionally, this is a very compact machine requiring minimal space and utility support meaning it is a perfect machine for minimum initial investment by a start-up company or one that is upgrading to fully automated production.



● Production Line in ASB's Indian Factory

■ Various Applications and Materials

Simple but effective fully automatic machine for the production of a wide variety of containers in any market. From six cavity 3~30ml container right up to 2.5L single cavity production is possible. As with all ASB Series machines, it has the flexibility to process materials other than PET including PP and PC.

Machine Specification	Unit	ASB-50MB v3
Standard Screw Diameter	mm	44
Theoretical Injection Capacity	cm ³	152*2
Injection Clamping Force	kN	60
Blow Clamping Force	kN	78
Driving Power (Rated)	kW	19.3
Heater Capacity (Rated)	kW	14*3
Oil Reservoir Capacity	L	250
Machine Size (L×W×H)	mm	3,770×1,170×2,947
Machine Mass (Approx.)	ton	3.0

● Specifications are subject to change without any obligation on the part of the manufacturer.
*2: Using the standard screw.
*3: Subject to container specification, number of cavity and mold.

■ A Useful Tool for Research & Development

The ASB-50MB could easily be used in a product development role as an economic and flexible test machine for projects that may be destined for multi-cavity production. Or, it might be used for testing new raw materials and processing techniques.

■ High Level Functions in an Economic Machine

A variety of specialized functions can be utilized including the use of a gate-cutter and champagne base operation*1 which allows high quality small containers to be molded with ease. The use of an electric servo for mold indexing ensures fast dry cycle and hygienic operation.

*1: Option

■ Typical Containers

- Applications :
Pharmaceuticals, cosmetics, liquor, infusion bottles, detergent, mouthwash, baby feeding bottles, spice, salad dressing, foods, mineral water etc.
- Materials :
PET, PP, PC, PEN, PS, PES, PPSU, recycled PET etc.
- Shapes :
Plain round, non-round, wide-mouth, oval, ultra-light etc.

Products Specification	Unit	ASB-50MB v3					
		1	2	3	4	5	(6)
Cavity Number	cavity	1	2	3	4	5	(6)
Max. Capacity	L	2.5	1.5	0.6	0.25	0.1	(0.03)
Max. Thread Diameter	T	mm	63	42	32	27	25 (17)
Max. Neck Diameter	E	mm	60	40	30	25	23 (15)
Max. Support Ring Diameter	SR	mm	63	42	32	27	25 (17)
Max. Body Diameter	BD	mm	115	90[100]*5	68[74]*5	56	45 (35)
Max. Width Parting Line	WD	mm	145	110	75	58	45 (35)
Max. Height	HB	mm	300			200	(150)
Max. Weight *4	g	129	65	43	32	26	(22)

● All figures are subject to container configuration. ● () Optional figure.
*4: Using standard screw and PET.
*5: Figures in brackets [] are applicable to HB<=200.



Best seller entry machine sold 2,000 units in the world. Compact & reasonable versatile machine.

Originally conceived as a low-cost entry machine for developing countries, this machine has rapidly become one of our best sellers, even in many highly developed markets.

In accordance with customer requirements, the specifications have been continually upgraded giving improved versatility and productivity. Over 2,000 units have now been delivered by our overseas factory since it was introduced.

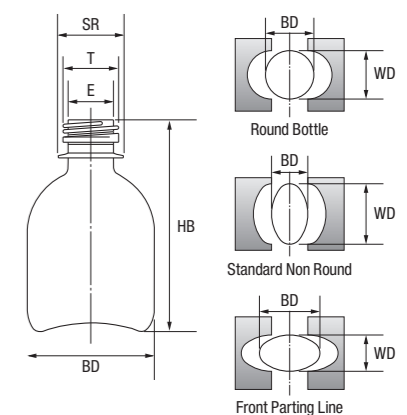

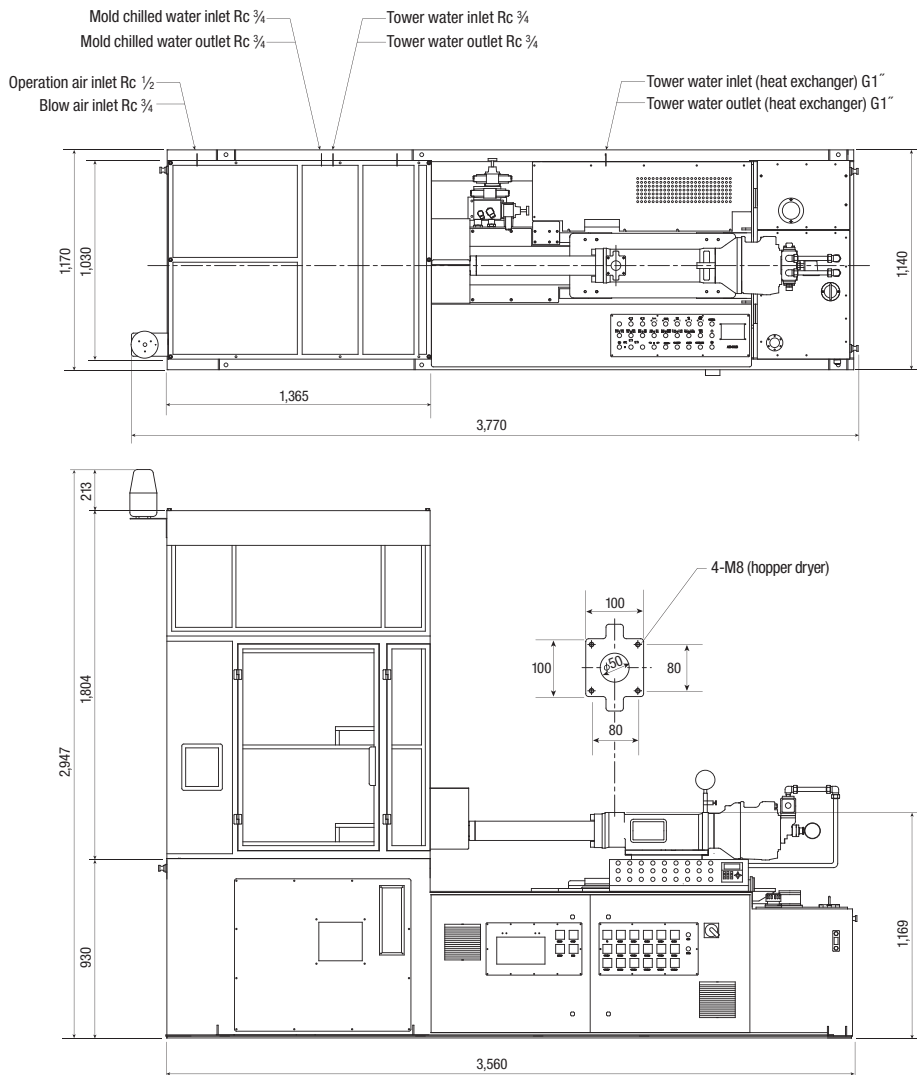

ASB®

NISSEI ASB MACHINE CO., LTD.

4586-3 Koo, Komoro-Shi, Nagano-Ken 384-8585, JAPAN
 TEL: 81 (267) 23-1565
 FAX: 81 (267) 23-1564
 E-Mail: sales@nisseiasb.co.jp
www.nisseiasb.co.jp/en/



www.youtube.com/user/NisseiASBMachine

Head Office and Factory
NISSEI ASB MACHINE CO., LTD.
 4586-3 Koo, Komoro-shi, Nagano-ken 384-8585, JAPAN
 TEL: 81 (267) 23-1565 FAX: 81 (267) 23-1564
 E-Mail: sales@nisseiasb.co.jp

U. S. A. and Canada
NISSEI ASB COMPANY
 125 Westlake Parkway Suite 120, Atlanta, Georgia 30336 U.S.A.
 TEL: 1 (404) 699-7755 FAX: 1 (404) 696-9009
 E-Mail: sales@nisseiasbus.com

Mexico, Central America
NISSEI ASB CENTRO AMERICA, S.A. DE C.V.
 Torres Adalid 618 1er Piso, Col. Del Valle C.P. 03100, México, D.F., MEXICO
 TEL: 52 (555) 669-00-69 FAX: 52 (555) 669-16-45
 E-Mail: info@asbcentroamerica.com

South America
NISSEI ASB SUDAMERICA LTDA.
 Av. Queiroz Filho nº 1.700 – Edifício Sky Tower – Conjunto 108
 Bairro Alto de Pinheiros – São Paulo – SP CEP: 05319-000, BRAZIL
 TEL: 55 (11) 3641-5353 FAX: 55 (11) 3831-9948
 E-Mail: sales@nisseiasb.com.br

UK and Ireland
NISSEI ASB LIMITED
 2 Milnyard Square, Bakewell Road, Orton Southgate,
 Peterborough PE2 6GX, UK.
 TEL: 44 (1733) 233544 FAX: 44 (1733) 235647
 E-Mail: sales@nisseiasb.co.uk

Europe, CIS, Turkey and Egypt
NISSEI ASB GmbH
 Mündelheimer Weg 58, 40472 Düsseldorf, GERMANY
 TEL: 49 (211) 94104-0 FAX: 49 (211) 94104-39
 E-Mail: nissei@nisseiasb.de

Iberia, Italy and Maghreb
NISSEI ASB MEDITERRANEA, S.L.U.
 Polígono Industrial Vallegón Pabellón 38, 39709
 Samano (Cantabria), SPAIN
 TEL: 34 (942) 87-1016 FAX: 34 (942) 86-7922
 E-Mail: nisseiasb@nisseiasbmediterranea.com

Middle East and Central Africa
NISSEI ASB FEZ
 Jebel Ali Free Zone (South) Warehouse No. FZ51B-H06
 P.O. Box: 16789, Dubai, U.A.E.
 TEL: 971 (4) 8860919 FAX: 971 (4) 8860918
 E-Mail: asbuae@emirates.net.ae

NISSEI ASB AFRICA LIMITED
 Novel House, Plot 3, Block J, Otunba Jobi Fele Way,
 Alausa CBD, Ikeja, Lagos, NIGERIA
 TEL: 234 (1) 8448167
 E-Mail: ASB_Africa@asbfze.ae

South & West Asia, Oceania, and Southern Africa
NISSEI ASB PTE. LTD.
 85 Science Park Drive #01-03 The Cavendish
 Singapore Science Park I SINGAPORE 118259
 TEL: 65-6778-4633 FAX: 65-6778-9440
 E-Mail: sales@nisseiasb.com.sg

ASB PTE (THAILAND) CO., LTD.
 124 Soi 1 Sukhumvit 62 Sukhumvit Road Bangchak Prakanong
 Bangkok 10260 THAILAND
 TEL: 66 (2) 311-7556/7557/7558 FAX: 66 (2) 741-7295
 E-Mail: asbpte@trueamail.com.th

NISSEI ASB SOUTH AFRICA (Pty) LTD.
 97 Sovereign Drive, Route 21 Corporate Park, Nelmapius Drive,
 Irene Ext.30, 0062, 0157, SOUTH AFRICA
 TEL: 27 (12) 345-4924 FAX: 27 (12) 345-5667
 E-Mail: sales@nisseiasb.co.za

PT. ASB INDONESIA
 Jl. Pangeran Jayakarta, No. 26, Block A-18, Jakarta Pusat 10730,
 INDONESIA
 TEL: 62 (21) 629-7978/5018 FAX: 62 (21) 629-5010
 E-Mail: asbindonesia@cbn.net.id

PHILIPPINES Office
 Unit 1703 Annapolis Wilshire Plaza No.11 Annapolis Street,
 Greenhills San Juan, Metro Manila, PHILIPPINES 1500
 TEL: 63 (2) 725-4220 FAX: 63 (2) 725-4203
 E-Mail: nisseiasb@smartrroadband.net.ph

VIETNAM Office
 Suite 601 6th Floor, Zen Plaza 54-56 Nguyen Trai Street,
 Dist. 1, Ho Chi Minh City, VIETNAM
 TEL: 84 (8) 3925-1008 FAX: 84 (8) 3925-1009
 E-Mail: nisseiasbhcm@vnn.vn

INDIA BRANCH Office
 309-311, Ansal Chambers-II 6, Bhikaji Cama Place,
 New Delhi 110 066, INDIA
 TEL: 91 (11) 2618-1615/2619-4031 FAX: 91 (11) 2619-4129
 E-Mail: asbdel@asbi.co.in

PAKISTAN Office
 401, Progressive Square 11-A, Block-6, P.E.C.H.S. Karachi 75400,
 PAKISTAN
 TEL: 92 (21) 3454-6533 FAX: 92 (21) 3453-7469
 E-Mail: asbpakistan@gmail.com

AUSTRALIA Office
 PO Box 1252, Camberwell, Victoria, 3124 AUSTRALIA
 TEL: 61 (418) 312-386
 E-Mail: asbaust@alphalink.com.au

SHANGHAI ASB TRADE CO., LTD.
 Room 1109, 339-1 Jiuxin Rd., Jiutong, Songjiang District,
 Shanghai 201615, CHINA
 TEL: 86 (21) 5763-0233 FAX: 86 (21) 5763-0699
 E-Mail: sales@shasb.com

ASB INTERNATIONAL PVT. LTD.
 E-9, MIDC, Industrial Area, Anand Nagar, Addl. Ambarnath,
 District-Thane-421506, Maharashtra, INDIA
 TEL: 91 (251) 262-5000/648-5070 FAX: 91 (251) 262-5035/5055
 E-Mail: sales@asbi.co.in