

One-Step Injection Stretch Blow Molding Machine

ASB Series

ASB-12M

Compact Machine with Jar Molding Capability and Advanced Efficiency

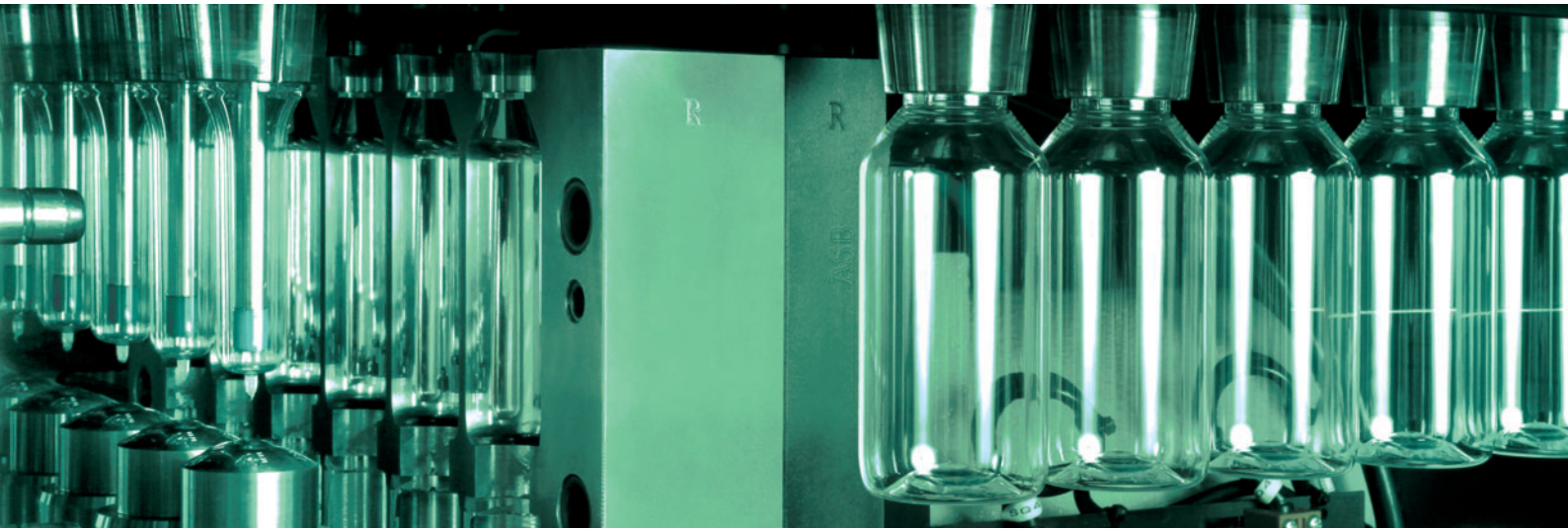



● Blow Mold and Take-out Station

Energy efficiency, Versatility, Low-noise, ASB-12M improved in every aspect.

A New Standard in Small Scale Injection Stretch Blow Molding.

The ASB-12M has been developed as an upgrade model from the entry level ASB-50MB, which has sold more than 2,000 units and remains in our line-up as one of our best sellers. It is a compact one-step injection stretch blow molding machine with improved jar capability and advanced energy efficiency.

Wider Range of Molded Containers



The ASB-12M can mold jars with necks up to $\phi 83\text{mm}$ thread diameter (typically up to 2 liters). Applications include many cosmetics, pharmaceutical

and food jars such as hand-cream, pill, peanut butter etc. Regular bottles of up to 2.5L can also be molded. In the smaller neck sizes, the productivity has also increased by 33% for $\phi 38\text{mm}$ neck and 66% for $\phi 32\text{mm}$ neck, compared with the ASB-50MB.

Not only PET, but various kind of plastics material such as PP and PC can easily be molded. This level of compactness together with high versatility and wider variety of neck size and cavitation is a first in this class of machine.

Low Noise

Besides energy reduction, noise and vibration are also dramatically reduced; now being on a similar level with ASB's all electric molding machine, the ASB-15N/10E. Smoother operation also results in greater durability and easier maintenance compared with the existing hydraulically operated models.

Improved Energy Efficiency

The ASB-12M utilizes two servo driven hydraulic pumps which can adapt their speed and output precisely to the required demand throughout the entire cycle of the machine thereby reducing actual energy consumption by about 40%*¹ compared with the ASB-50MBv3. In tests, actual power consumption was measured at approx. 25% of the rated power.

*¹: Subject to container configuration.

Ideal for Low-volume High-mix Production

The ASB-12M can produce a huge variety of high-quality containers. It is small enough to be used as a laboratory testing machine while also having the capability to offer serious production output.

The molds are light and simple meaning that mold changes can be performed without any special lifting equipment resulting in quick and easy mold changeovers.

Workability

Design changes in the control panel ensure easier mold change and maintenance over previous models.

Existing Machine's Mold can be Mounted

Molds made for the existing ASB-12N/10 and ASB-50MBv3 can be converted to mount on the ASB-12M.*² *³ *⁴ This enables easy upgrade path for ASB's customers who are already using these existing machines.

*²: For ASB-50MB molds the conversion may be complex so a new purpose made ASB-12M mold may be more economic.

*³: Molds for ASB-12M cannot be mounted on the other machines.

*⁴: Please contact your local ASB representative for the details.

Machine Specification	Unit	ASB-12M
Standard Screw Diameter	mm	44
Theoretical Injection Capacity	cm ³	152* ¹
Injection Clamping Force	kN	137
Blow Clamping Force	kN	116
Driving Power (Rated)	kW	29.8
Heater Capacity (Rated)	kW	16.1* ²
Oil Reservoir Capacity	L	220
Machine Size (L×W×H)	mm	4,320×1,210×3,103
Machine Mass (Approx.)	ton	4.0

● Specifications are subject to change without any obligation on the part of the manufacturer.

● Note: Actual power consumption example: 100g shot weight, 14.6 sec/cycle = approx. 25% of rated power.

*¹: Using the standard screw.

*²: Subject to container specification, number of cavities and mold.

Products Specification	Unit	ASB-12M							
		1	2	3	4	5	6	(7)	(8)
Cavity Number	cavity	1	2	3	4	5	6	(7)	(8)
Max. Capacity	L	2.5	1.5	0.9	0.4	0.25	0.1	(0.03)	(0.02)
Max. Thread Diameter	T mm	83	62	48	38	32	25	(17)	(15)
Max. Neck Diameter	E mm	79	60	43	33	28	23	(15)	(13)
Max. Support Ring Diameter	SR mm	80	62	45	38	32	25	(17)	(15)
Max. Body Diameter	BD mm	118	90[100]* ⁴	66[85]* ⁴	54[69]* ⁴	56	45	(28)	(26)
Max. Width Parting Line	WD mm	145	113	85	67	56	45	(28)	(28)
Max. Height	HB mm	300			200			(150)	
Max. Weight * ³	g	129	65	43	32	26	22	(18)	(16)

● All figures are subject to container configuration. ● () Optional feature

*³: Using standard screw and PET.

*⁴: Figures in brackets [] are applicable to HB<=200.

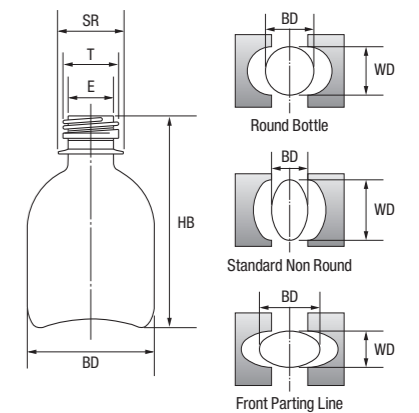

Typical Containers

- Applications: Wide mouthed jars for a variety of food and non-food applications, Cosmetics (mascara, lotion, cream etc.), pharmaceuticals (eye drops, medicine, pills etc.), baby feeding bottles, spice, liquor, carbonated drink etc.
- Materials: PET, PP, PC, PEN, PS, PES, PPSU, recycle PET etc.
- Shapes: Plain round, wide-mouth, oval, non-round, ultra-light etc.

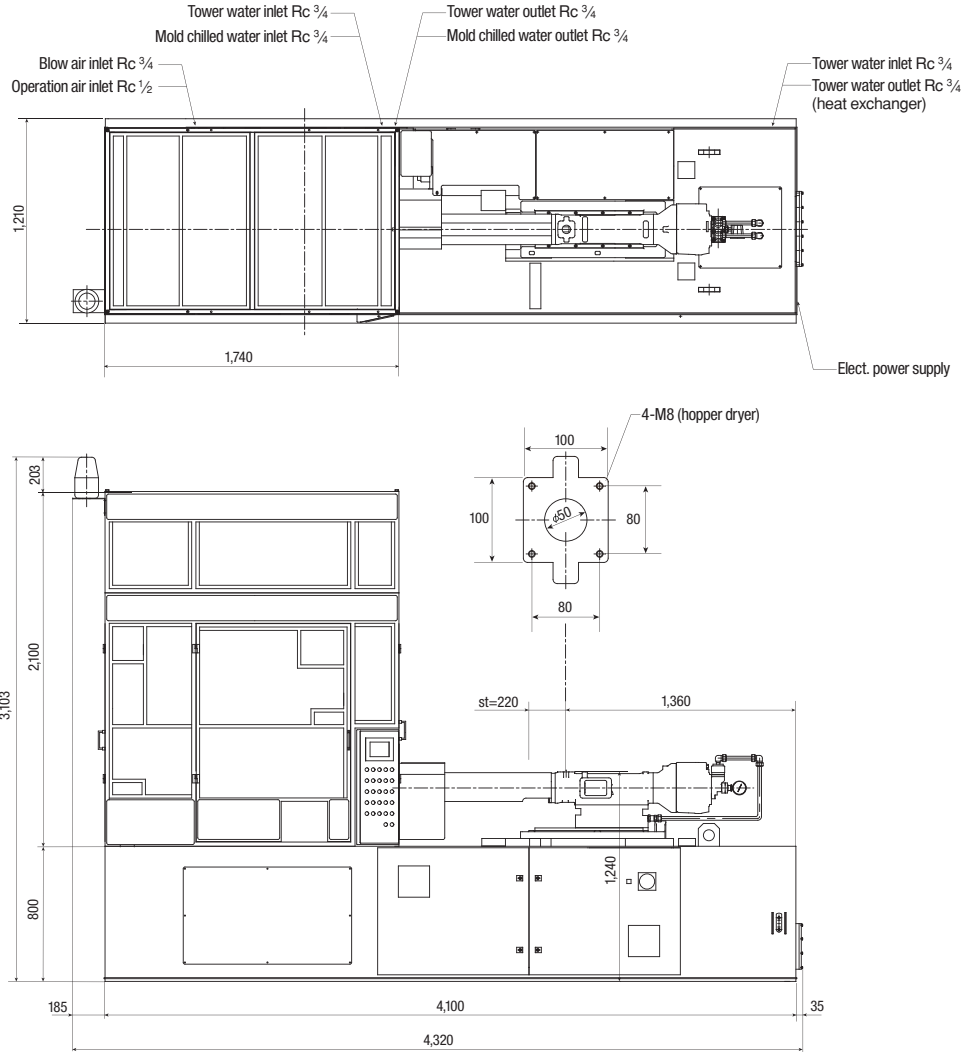

ASB®

NISSEI ASB MACHINE CO., LTD.

4586-3 Koo, Komoro-Shi, Nagano-Ken 384-8585, JAPAN
 TEL: 81 (267) 23-1565
 FAX: 81 (267) 23-1564
 E-Mail: sales@nisseiasb.co.jp
www.nisseiasb.co.jp/en/



www.youtube.com/user/NisseiASBMachine

Head Office and Factory
NISSEI ASB MACHINE CO., LTD.
 4586-3 Koo, Komoro-shi, Nagano-ken 384-8585, JAPAN
 TEL: 81 (267) 23-1565 FAX: 81 (267) 23-1564
 E-Mail: sales@nisseiasb.co.jp

U. S. A. and Canada
NISSEI ASB COMPANY
 125 Westlake Parkway Suite 120, Atlanta, Georgia 30336 U.S.A.
 TEL: 1 (404) 699-7555 FAX: 1 (404) 696-9009
 E-Mail: sales@asbus.com

Mexico, Central America
NISSEI ASB CENTRO AMERICA, S.A. DE C.V.
 Torres Adalid 618 1er Piso, Col. Del Valle C.P. 03100, México, D.F., MEXICO
 TEL: 52 (555) 669-00-69 FAX: 52 (555) 669-16-45
 E-Mail: info@asbcentroamerica.com

South America
NISSEI ASB SUDAMERICA LTDA.
 Av. Queiroz Filho nº 1.700 – Edifício Sky Tower – Conjunto 108
 Bairro Alto de Pinheiros – São Paulo – SP CEP: 05319-000, BRAZIL
 TEL: 55 (11) 3641-5353 FAX: 55 (11) 3831-9948
 E-Mail: sales@nisseiasb.com.br

UK, and Ireland
NISSEI ASB LIMITED
 2 Milnyard Square, Bakewell Road, Orton Southgate,
 Peterborough PE2 6GX, UK.
 TEL: 44 (1733) 233544 FAX: 44 (1733) 235647
 E-Mail: sales@nisseiasb.co.uk

Europe, CIS, Turkey and Egypt
NISSEI ASB GmbH
 Mündelheimer Weg 58, 40472 Düsseldorf, GERMANY
 TEL: 49 (211) 94104-0 FAX: 49 (211) 94104-39
 E-Mail: nissei@nisseiasb.de

Iberia, Italy and Maghreb
NISSEI ASB MEDITERRANEA, S.L.U.
 Polígono Industrial Vallegón Pabellón 38, 39709
 Samano (Cantabria), SPAIN
 TEL: 34 (942) 87-1016 FAX: 34 (942) 86-7922
 E-Mail: nisseiasb@nisseiasbmediterranea.com

Middle East and Central Africa
NISSEI ASB FZE
 Jebel Ali Free Zone (South) Warehouse No. FZ51B-H06
 P.O. Box: 16789, Dubai, U.A.E.
 TEL: 971 (4) 8860919 FAX: 971 (4) 8860918
 E-Mail: asbuae@emirates.net.ae

NISSEI ASB AFRICA LIMITED
 Novel House, Plot 3, Block J, Otunba Jobi Fele Way,
 Alausa CBD, Ikeja, Lagos, NIGERIA
 TEL: 234 (1) 8448167
 E-Mail: ASB_Africa@asbfze.ae

South & West Asia, Oceania, and Southern Africa
NISSEI ASB PTE. LTD.
 85 Science Park Drive #01-03 The Cavendish
 Singapore Science Park I SINGAPORE 118259
 TEL: 65-6778-4633 FAX: 65-6778-9440
 E-Mail: sales@nisseiasb.com.sg

ASB PTE (THAILAND) CO., LTD.
 124 Soi 1 Sukhumvit 62 Sukhumvit Road Bangchak Prakanong
 Bangkok 10260 THAILAND
 TEL: 66 (2) 311-7556/7557/7558 FAX: 66 (2) 741-7295
 E-Mail: asbpte@trueaimail.com.th

NISSEI ASB SOUTH AFRICA (PTY) LTD.
 977 Sovereign Drive, Route 21 Corporate Park, Nelmapius Drive,
 Irene Ext.30, 0062, 0157, SOUTH AFRICA
 TEL: 27 (12) 345-4924 FAX: 27 (12) 345-5667
 E-Mail: sales@nisseiasb.co.za

PT. ASB INDONESIA
 Jl. Pangeran Jayakarta, No. 26, Block A-18, Jakarta Pusat 10730,
 INDONESIA
 TEL: 62 (21) 629-7978/5018 FAX: 62 (21) 629-5010
 E-Mail: asbindonesia@cbn.net.id

PHILIPPINES Office
 Unit 1703 Annapolis Wilshire Plaza No.11 Annapolis Street,
 Greenhills San Juan, Metro Manila, PHILIPPINES 1500
 TEL: 63 (2) 725-4220 FAX: 63 (2) 725-4203
 E-Mail: nisseiasb@smartbroadband.net.ph

VIETNAM Office
 Suite 601 6th Floor, Zen Plaza 54-56 Nguyen Trai Street,
 Dist. 1, Ho Chi Minh City, VIETNAM
 TEL: 84 (8) 3925-1008 FAX: 84 (8) 3925-1009
 E-Mail: nisseiasbhm@gmail.vn

INDIA BRANCH Office
 309-311, Ansal Chambers-II 6, Bhikaji Cama Place,
 New Delhi 110 066, INDIA
 TEL: 91 (11) 2618-1615/2619-4031 FAX: 91 (11) 2619-4129
 E-Mail: asbdel@asbi.co.in

PAKISTAN Office
 401, Progressive Square 11-A, Block-6, P.E.C.H.S. Karachi 75400,
 PAKISTAN
 TEL: 92 (21) 3454-6533 FAX: 92 (21) 3453-7469
 E-Mail: asbpakistan@gmail.com

AUSTRALIA Office
 PO Box 1252, Camberwell, Victoria, 3124 AUSTRALIA
 TEL: 61 (418) 312-386
 E-Mail: asbaust@alphalink.com.au

China
SHANGHAI ASB TRADE CO., LTD.
 Room 1109, 339-1 Jiuxin Rd., Jiuting, Songjiang District,
 Shanghai 201615, CHINA
 TEL: 86 (21) 5763-0233 FAX: 86 (21) 5763-0699
 E-Mail: sales@shasb.com

Overseas Factory and Sales
ASB INTERNATIONAL PVT. LTD.
 E-9, MIDC, Industrial Area, Anand Nagar, Addl. Ambarnath,
 District-Thane-421506, Maharashtra, INDIA
 TEL: 91 (251) 262-5000/648-5070 FAX: 91 (251) 262-5035/5055
 E-Mail: sales@asbi.co.in